

Seals + Direct Ltd

Unit 6
Milton Business Centre
Wick Drive
New Milton
Hants
BH25 6RH

Tel: 0845 226 3345 (local rate) or 01425 617722

Fax: 0845 226 3343 (local rate) or 01425 610967

E-mail: sales@sealsplusdirect.co.uk

REFURBISHING ALUMINIUM FRAMED WINDOWS

FIXED WINDOWS

Over a period of time the rubber seals in window frames tend to deteriorate and start to let in water. The only option is to replace it with a new seal. Temporary repairs can be made using a silicone sealant, but these don't last very long.

The following procedures should be followed.

- Remove all the fixing screws from the frame. This is normally a two-person job, as you need one at either end of the fixing screws.
- Carefully remove the window frame from the aperture making sure that you do not apply pressure to the frame and bend it. If the frame has been bonded in place with mastic, use a flat bladed scraper and ease it around the joint until the old mastic gives way.
- The first thing to do is to clean up the old frame and rid it of all the old sealant. Avoid using sharp scrapers as these can damage the Aluminium.
- The frame is normally made up from sections. At each joint remove the screws that hold the joining strip in place. Carefully tap a thin flat scraper blade, or similar into the joint, taking care not to damage the frame. Repeat this on each joint gradually opening up the frame until it is separated. Remove the seal and window.
- Due to the marine environment it is advisable to soak all items in a bath of fresh water for a couple of hours. This will help loosen and dissolve any residue salt deposits. After the parts are dry more cleaning is required on the frame.
- The next job is to check the condition of the window and seal. Most windows now days are made from Perspex. This is an excellent material but does deteriorate over a long period of time. If you wish to replace it draw round it onto brown paper and send it to us for a quotation. It is a false economy to use an old seal and it is always advisable to replace it. To determine the correct size of seal you require three main dimensions are needed.

Glass/Perspex thickness

Internal width of the Aluminium channel

Internal depth of Aluminium channel

To match your required rubber U channel to the available sizes firstly measure the glass/Perspex, then check the table of available sections to suit this in our catalogue or on our website. Next check the U channel's wall thickness and add twice this to the glass/Perspex size. This will give you the overall rubber width to ensure that it fits into your Aluminium channel. Be aware that the 70° sh EPDM rubber U channel will not compress significantly. If you are unable to locate the exact size in our catalogue, you can either modify one of our existing seals, or contact us with your requirements and we will try and source it for you. Many seals used in old windows are no longer available and modern day equivalents have to be used.

Rubber U channel

- Cut the new seal to length (slightly oversize to prevent it shrinking back over time) and do a dry fit assembly to ensure that everything fits together OK. Dismantle and then apply a small bead of marine grade high modulus silicone sealant inside the rubber. Place the seal around the glass/Perspex. Now apply a small bead of silicone sealant into the bottom of the Aluminium frame. Carefully place the window and seal into the frame and pull all bits together until they are in the correct position. (You may require the use of clamps to pull the frame together). Now replace the screws into the joining strips.
- To ensure that you have a watertight window it is advisable to apply a fillet of silicone around the top edge of the seal and frame. Mask off the frame and the window leaving about a 6mm gap. Apply the silicone and then smooth it off using a blunt instrument or wet finger. Carefully remove the masking tape whilst the silicone is wet.

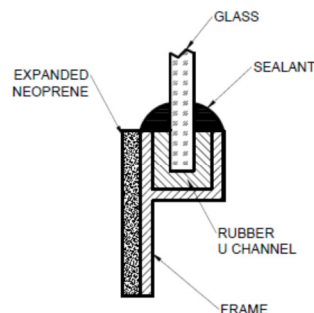

Using Wedge seals and gaskets

- At the bottom of the Aluminium channel run a strip of expanded neoprene so that the glass/Perspex has a soft cushion to sit on. Apply a small bead of silicone sealant onto the face of the expanded neoprene and assemble the frame around the glass/Perspex ensuring that it is sitting centrally. Depending on the size of the frame you can either have a wedge gasket on one side with expanded neoprene on the other, or a wedge gasket on both sides.

If using the expanded neoprene a 30% compression should be allowed for. i.e. The glass/Perspex + the neoprene + the wedge seal total should be 30% bigger than the internal channel width.

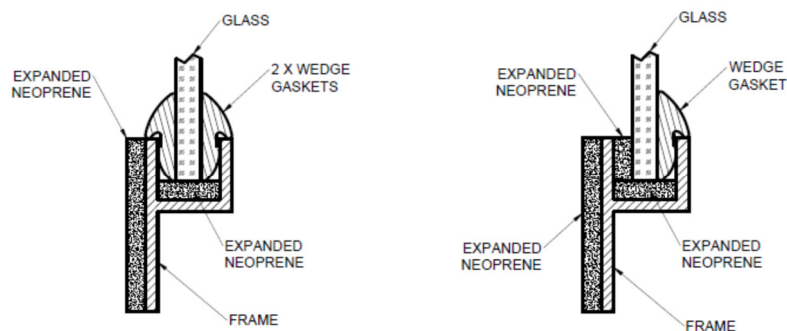

- When refitting the completed window into the boat you will require a seal to go between the frame and the cabin side. The best material to use is a closed cell expanded neoprene, about 3mm thick and slightly wider than the flange. (This can be trimmed off when the window is fully fitted). Apply this to the frame and pre drill the bolt holes. Just before fitting the window to the boat smear a small amount of silicone sealant onto the top face of the seal. This will accommodate any minor imperfections and stop any leaks. Fit the screws and tighten up **to** achieve a 30% compression on the seal. Carefully trim the expanded neoprene around the edge of the frame using a sharp knife, and wipe away any excess sealant.

SLIDING WINDOWS

Over a period of time the seals in sliding windows tend to wear and deteriorate. Old windows used to use either a felt or webbing material, but these have now been replaced with a velvet-covered rubber. There are two main types: a preformed U shape, or a flat strip that bends to fit inside a channel.

- Dismantle and clean the windows as above. Measure you frame and glass/Perspex to determine the correct size of seal. You may have to modify one of the seals to fit the channel correctly. (For example put a strip of neoprene under it or to one side to increase its height or width).
- The key dimensions are the width of the glass/Perspex and the internal width of the channel.
- Apply a small bead of marine grade silicone sealant into the bottom of the channel and press the seal into place. Replace the glass/Perspex and reassemble the frame.
- Refit the frame into the boat as above.

